

Exercises on Force and Motion

Exercise 1.1

A small object is subject to two forces. One force has a magnitude of 5 units and a direction due East. The other force has a magnitude of 10 units and a direction of 37° North of West. What is the net force on the object?

Since forces combine according to the rules of vector addition, we need to express each force as a vector and then add the two vectors. The easiest way to add vectors is to express them in terms of the unit vectors \hat{i} which points in the $+x$ direction and \hat{j} which points in the $+y$ direction. If we let \vec{A} be the first vector, then $\vec{A} = 5\hat{i}$. If we let \vec{B} be the second vector, then $\vec{B} = -8\hat{i} + 6\hat{j}$. We obtained these components because $10\cos 30^\circ \approx 8$, and $10\sin 30^\circ \approx 6$. Adding the two vectors gives:

$$\begin{aligned}\vec{F}_{net} &= \vec{A} + \vec{B} \\ &= (5 - 8)\hat{i} + (0 + 6)\hat{j} \\ &= -3\hat{i} + 6\hat{j}\end{aligned}$$

We could leave the answer in this form, but it is useful to know the magnitude and direction of the net force. To find the magnitude, we use Pythagorus' Theorem: $|\vec{F}_{net}| = \sqrt{3^2 + 6^2} \approx 6.71$ units of force. To find the direction, we use $\tan\theta = 6/3 = 2$, which gives $\theta \approx 63.4^\circ$. Since this is the angle that the vector makes with the negative x-axis, the direction is 63.4° North of West. The vector is in the second quadrant.

One could also ask: What force would balance these two? It would be a force opposite to \vec{F}_{net} , which would have a magnitude of 6.71 units and in a direction 63.4° South of East. In terms of the unit vectors, the balancing force would be $3\hat{i} - 6\hat{j}$.

Exercise 1.2

A golfer wants to putt the ball into the hole. The hole lies a distance of 20 feet due North of the ball. The golfer putts the ball a distance of 21 feet at an angle of 10° West of North. How far and in what direction should he putt the ball to make it into the hole?

In class we demonstrated that displacements add according to the rules of vector addition. If we let \vec{C} be the original displacement to the hole, and \vec{A} the displacement

of the first putt, then the displacement for the second putt to reach the hole is $\vec{B} = \vec{C} - \vec{A}$. The vector \vec{C} is equal to $20\hat{j}$, and $\vec{A} = -21\sin 10^\circ \hat{i} + 21\cos 10^\circ \hat{j} \approx -3.65\hat{i} + 20.7\hat{j}$. Thus, the displacement of the second putt should be

$$\begin{aligned}\vec{B} &= \vec{C} - \vec{A} \\ &= 20\hat{j} - (-3.65\hat{i} + 20.7\hat{j}) \\ &\approx (0 - (-3.65))\hat{i} + (20 - 20.7)\hat{j} \\ &\approx 3.65\hat{i} - 0.7\hat{j}\end{aligned}$$

In terms of the direction and magnitude, the second putt should be a distance of $|\vec{B}| = \sqrt{3.65^2 + 0.7^2} \approx 3.72$ units. The direction of the second putt should be $\tan\theta = 0.7/3.65$ or $\theta \approx 10.8^\circ$. The vector \vec{B} is in the 4th quadrant, so the direction is 10.8° South of East.

Exercise 1.3

Wolfram wants to determine the weight of an object by using ropes and pulleys. He hangs two 100 pound weights around two pulleys as shown in the figure. He hangs an unknown weight, W , from the rope in the middle. As the weight W hangs, the ropes are pulled down and make an angle of 20° with the horizontal. What is the unknown weight W in pounds?

If we look at the point where the weight hangs, the three forces must add up to zero. That is, the sum of the two 100 pound forces directed upward 20° from the horizontal must equal the weight W . The left and right components cancel out (each being equal to $100\cos 20^\circ$). Thus, in the vertical direction we must have:

$$\begin{aligned}W &= 2(100)\sin 20^\circ \\ &\approx 68.4 \text{ pounds}\end{aligned}$$

Exercise 1.4

In the figure (1.4) a 100 pound weight is supported by two ropes. One rope has a tension T_1 and pulls at an angle of 53° above the horizontal. The other rope has a tension T_2 and pulls at an angle of 37° above the horizontal. Find the values of T_1 and T_2 .

Since the system is in static equilibrium, all the forces must add up to zero. That is, $\vec{W} + \vec{T}_1 + \vec{T}_2 = 0$. Using a coordinate system with the x-axis horizontal, we have

1.1

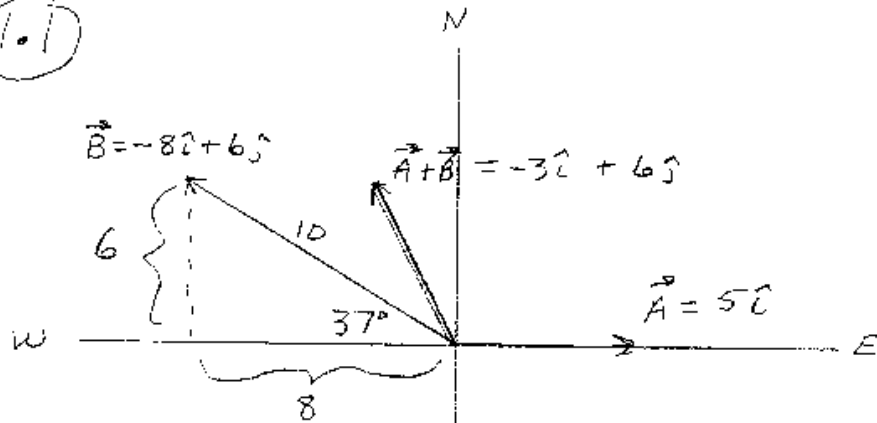

$$|\vec{A} + \vec{B}| = \sqrt{3^2 + 6^2} = \sqrt{45} \approx 6.71$$

1.2

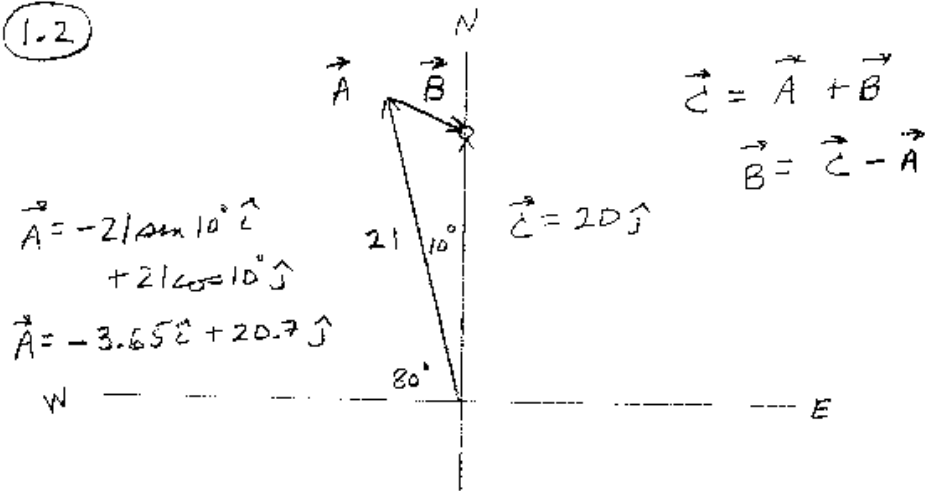

$$\begin{aligned}
\vec{W} &= -100\hat{j} \\
\vec{T}_1 &= T_1\cos(53^\circ)\hat{i} + T_1\sin(53^\circ)\hat{j} \\
\vec{T}_2 &= -T_2\cos(37^\circ)\hat{i} + T_2\sin(37^\circ)\hat{j}
\end{aligned}$$

where $T_1 = |\vec{T}_1|$ and $T_2 = |\vec{T}_2|$. Since these three vectors must add to zero, we have:

$$\begin{aligned}
T_1(0.6) &= T_2(0.8) \\
100 &= T_1(0.8) + T_2(0.6)
\end{aligned}$$

since $\cos(53^\circ) = \sin(37^\circ) \approx 0.6$ and $\cos(37^\circ) = \sin(53^\circ) \approx 0.8$. Solving these two equations for T_1 and T_2 yields: $T_1 \approx 80$ pounds and $T_2 \approx 60$ pounds.

Exercise 2.1

Eva sprints the 100 meter dash. When she starts off, she increases her speed with a constant acceleration of 2 m/s^2 . She keeps up this constant acceleration till she reaches a speed of 10 m/s . Then she continues the race at this constant velocity. What is her time for the 100 meter dash?

Let's first find the time that she is accelerating. She starts off at rest and accelerates till she reaches a speed of 10 m/s . Since her acceleration is 2 m/s^2 , this will take her a time of $10/2 = 5$ seconds. During the acceleration period, she will travel a distance of $d = (a/2)t^2 = (2/2)5^2 = 25 \text{ meters}$. The last 75 meters she will travel at a constant speed of 10 m/s . This will take her $75/10 = 7.5 \text{ sec}$. Therefore, her total time for the 100 meters is $5 + 7.5 = 12.5 \text{ sec}$.

Exercise 2.2

Alfred has a theory about how objects fall. He believes that an object falls with an acceleration that increases as a constant rate. That is, the acceleration is $a = ct$ where c is a constant. To determine c he measures the time it takes an object to fall 1 meter starting from rest. He finds that it takes 0.45 seconds to fall 1 meter. What is the constant c ?

1.3

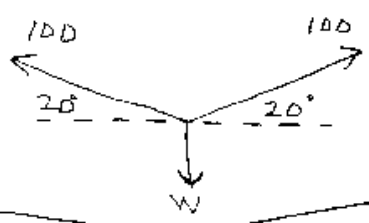
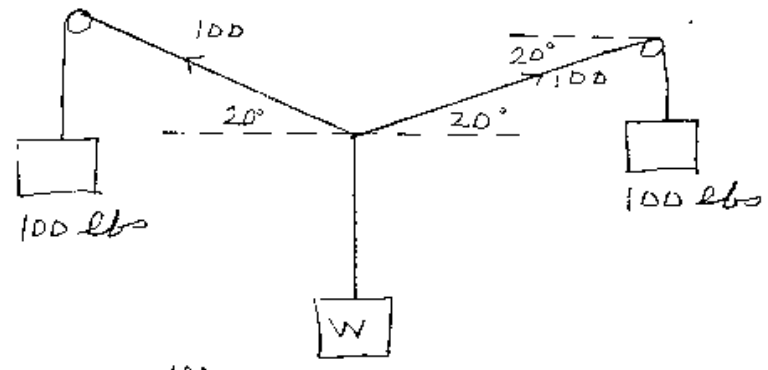

$$W = 2(100) \sin 20^\circ$$

1.4

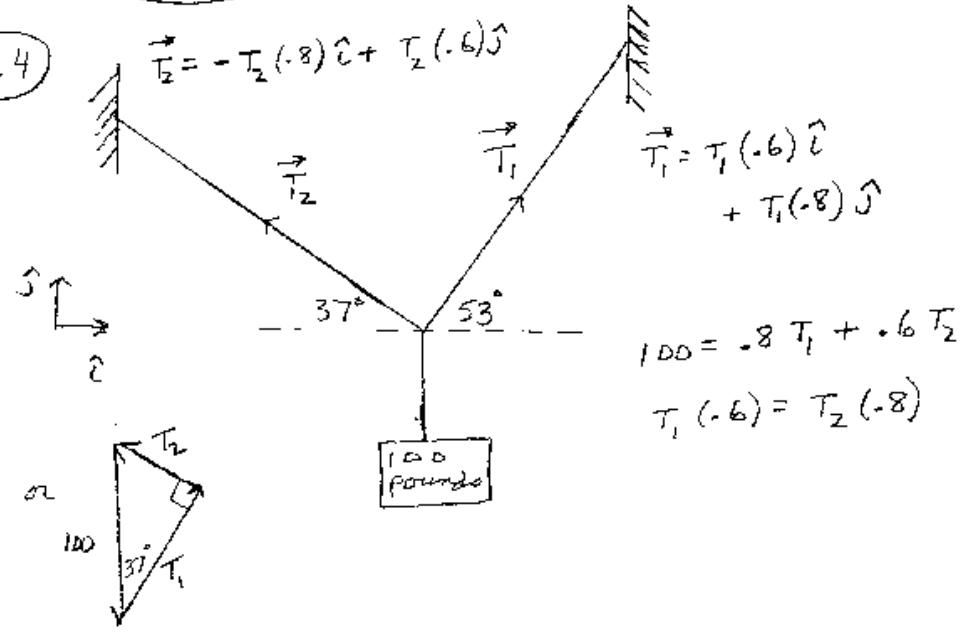

$$\vec{T}_2 = -T_2(0.8)\hat{i} + T_2(0.6)\hat{j}$$

$$\vec{T}_1 = T_1(-0.6)\hat{i} + T_1(0.8)\hat{j}$$

$$100 = -0.8 T_1 + 0.6 T_2$$

$$T_1(-0.6) = T_2(-0.8)$$

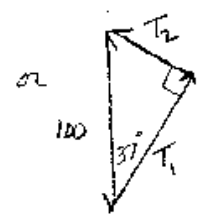

Since we know the acceleration, $a = ct$, we can find how the speed changes in time. Since $dv/dt = a = ct$ we have

$$\begin{aligned}\frac{dv}{dt} &= ct \\ v &= \int ct \, dt \\ v &= \frac{ct^2}{2} + K\end{aligned}$$

where K is an integrating constant. Since $v = 0$ at $t = 0$, $K = 0$. We can integrate one more time to find x since $dx/dt = v = ct^2/2$.

$$\begin{aligned}\frac{dx}{dt} &= \frac{ct^2}{2} \\ x &= \int \frac{ct^2}{2} dt \\ x &= \frac{ct^3}{6} + K\end{aligned}$$

where K is an integrating constant. Since $x = 0$ at $t = 0$, $K = 0$. Thus, the position as a function of time is $x = ct^3/6$. Since $x = 1$ meter when $t = 0.45$ seconds, we have $1 = c(0.45)^3/6$. Solving for c gives $c \approx 67.1 \text{ m/s}^3$.

b) If the model is correct, how long will it take for an object to fall 5 meters?

To find the time to fall 5 meters, we just solve for t in the following equation: $5 = (67.1)t^3/6$. Solving for t in this equation gives 0.76 seconds. If the experiment is performed, Alfred will find out that it takes around 1 second to fall 5 meters. Thus, his theory does not match the data and must be discarded.

Exercise 2.3

Connie, the policewoman, is sitting in her car when a speeding driver passes by. The driver is traveling at a constant speed of 150 ft/s (around 100 miles/hr). Just as the driver passes, Connie takes off from rest with a constant acceleration of 10 ft/s^2 .

How long does it take Connie to catch up to the speeding driver?

Let d_1 be the distance that the driver is from where Connie was parked. Since the driver is traveling at a constant velocity, $d_1 = 150t$, where t is in seconds. Let d_2 be Connie's distance from where she was parked. Since her acceleration is constant, 10 ft/s , and her initial velocity is 0, $d_2 = (10/2)t^2 = 5t^2$. We can solve for the time for Connie to catch the speeder by setting $d_1 = d_2$:

$$\begin{aligned}150t &= 5t^2 \\ t &= 30 \text{ seconds}\end{aligned}$$

b) What is Connie's velocity when she catches the speeder?

Since her acceleration is constant, her velocity is $v(t) = 10t$. So after 30 seconds her speed is 300 ft/s , or around 200 Mi/hr. It is pretty hard to keep increasing your speed at a constant rate.

Exercise 2.4

Alex is juggling tennis balls. He throws a ball upward with a speed v_0 , and it rises to a height h_0 . If he wants the tennis ball to go twice as high, how fast must he throw it upward?

During its flight upward, the tennis ball has a constant acceleration, g , directed downward if we neglect air friction. At the top of the flight, the velocity is zero, so we can use the equation that relates speed to distance for **constant acceleration**: $v_f^2 = v_i^2 + 2ax$. For our problem, $v_i = v_0$, $v_f = 0$, $a = -g$, and $x = h_0$. So we have

$$0 = v_0^2 - 2gh_0 \tag{1}$$

Solving for h_0 we have $h_0 = v_0^2/(2g)$. In general, for an initial velocity v_i the height that the ball will rise is $h = v_i^2/(2g)$. From this equation, we can see that if h is to double, then the initial velocity must be increased by a factor of $\sqrt{2}$. So $v_i = \sqrt{2}v_0$. One can also write this as a ratio:

$$\frac{h}{h_0} = \frac{v_i^2/(2g)}{v_0^2/(2g)}$$

$$\frac{h}{h_0} = \left(\frac{v_i}{v_0}\right)^2$$

$$h = h_0\left(\frac{v_i}{v_0}\right)^2$$

or

$$v_i = v_0\sqrt{h/h_0} \tag{2}$$

If $h = 2h_0$, then $v_i = \sqrt{2}v_0$. For constant negative acceleration, the stopping distance is proportional to the velocity squared. Remember this when you are driving. If you double your speed, it will take you 4 times the distance to stop!

Exercise 2.5

Iris is standing on the side of a cliff. She drops a rock. Then one second later she throws a second rock down with a speed of 64 ft/s . The rocks hit the bottom of the cliff at the same time. How high is the cliff?

Let $t = 0$ correspond to when she throws down the second rock. Letting "down" be the $+$ direction, the distance that the first rock has fallen from the edge of the cliff is $d_1 = (g/2)(t+1)^2$ if we neglect the effects of air friction. We need to use $t+1$ since at $t = 0$ the first rock has already traveled for a time of one second. The distance of the second rock has fallen from the top of the cliff is $d_2 = v_0t + (g/2)t^2$. In these equations, $g = 32 \text{ ft/s}^2$ and $v_0 = 64 \text{ ft/s}$. They both hit the bottom at the same time. We can solve for this time by setting $d_1 = d_2$:

$$16(t+1)^2 = 64t + 16t^2$$

$$16t^2 + 32t + 16 = 64t + 16t^2$$

$$t = 0.5$$

Thus, the rocks land 0.5 seconds after the second rock is thrown down. We can plug in t into either side of the equation to find the height of the cliff. The height of the cliff is $h = 16(1.5)^2 = 36$ feet. There would have been an easier way to find the height of the cliff. Just time how long it takes a rock to fall. In this case one would have measured 1.5 seconds for the first rock to hit the ground. Then $h = 16(1.5)^2 = 36$ feet.

2.4

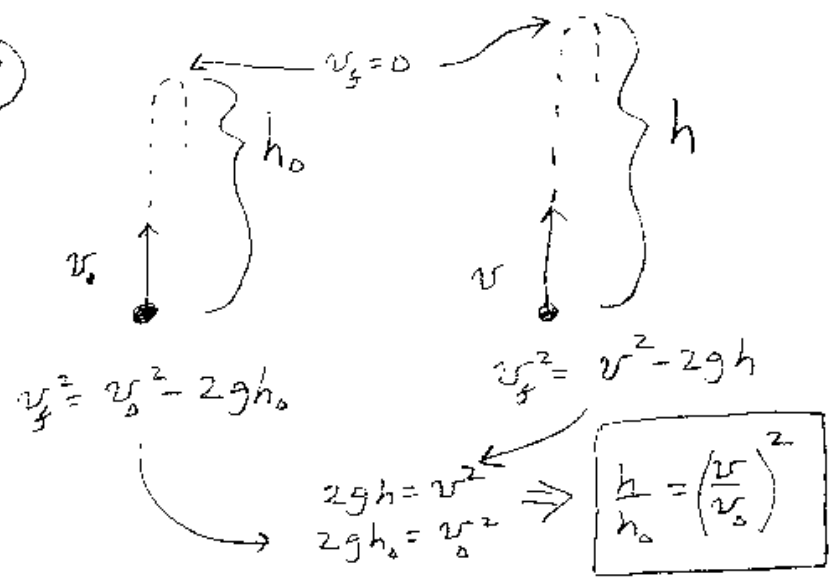

2.8

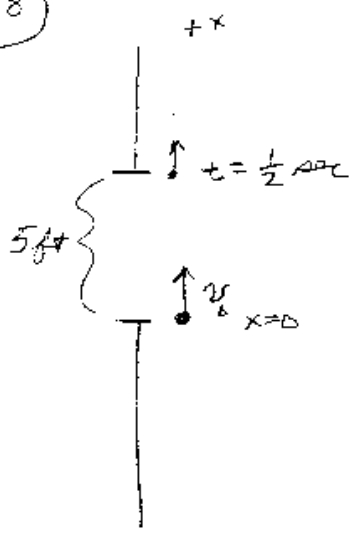

$$x = \frac{a}{2}t^2 + v_0 t + x_0$$

$$x = \frac{-32}{2}t^2 + v_0 t$$

$$x = -16t^2 + v_0 t$$

at $t = \frac{1}{2}$ $x = 5$

$$5 = -16\left(\frac{1}{2}\right)^2 + v_0\left(\frac{1}{2}\right)$$

$$v_0 = 18 \text{ ft/s}$$

Exercise 2.6

The California Department of Motor Vehicle Handbook states that if one is driving at a speed of 65 mph and applies the brakes, then it takes a distance of 234.7 feet to come to a stop. What value for acceleration does the DMV use for a car?

If we assume that the car slows down with *a constant acceleration* then we can solve the problem. For motion that is constant acceleration we have two main relationships: $x(t) = (a/2)t^2 + v_0t + x_0$ and $v^2 = v_0^2 + 2a(x - x_0)$. Since we are not interested in the position or velocity at a particular *time*, then the second equation is best suited for us. Let's change v_i to ft/s since $x - x_0 = 234.7$ feet. 65 mph corresponds to 95.3 ft/s. Since $v_f = v = 0$ (the car comes to rest), we have:

$$\begin{aligned}0 &= 95.3^2 + 2a(234.7) \\ a &= -19.3 \text{ ft/s}\end{aligned}$$

The negative sign means the acceleration is in the "-" direction. In this case, the acceleration is in the opposite direction to the velocity.

Exercise 2.7

Gary has unbreakable glasses, which means that they can withstand a collision with the floor up to a speed of 5 m/s. Peter wants to check it out, so he drops them from a height of 2 meters. Do the glasses break when they hit the floor?

This is another case of constant acceleration. Since we are not interested in the time, we can use $v^2 = v_i^2 + 2a(x - x_0)$. Taking down as the "+" direction, we have $v_i = 0$, and $a = g \approx 9.8 \text{ m/s}^2$:

$$\begin{aligned}v^2 &= 0 + 2(9.8)(2) \\ v &= 6.26 \text{ m/s}\end{aligned}$$

Opps, the glasses break.

Exercise 2.8

Grace is looking out her window, and sees a ball travel upward. It takes 1/2 second to pass the opening of the window, which has an opening of 5 feet.

a) What is the speed of the ball as it enters the bottom of the window.

Since the acceleration of the ball is approximately constant (i.e. g), we can use for expressions for constant acceleration. Let $x = 0$ be the bottom of the window, and let the "+" direction be upward. Thus, $x(t) = -(g/2)t^2 + v_0t$. Using feet as our unit for distance, $g = 32$ ft/s. Since $x(t = 1/2) = 5$, we have

$$\begin{aligned} 5 &= -(32/2)(1/2)^2 + v_0(1/2) \\ v_0 &= 18 \text{ ft/s} \end{aligned}$$

Thus, the position of the ball at any time t is $x = 18t - 16t^2$, and its velocity is $v = 18 - 32t$. The ball reaches its highest point when $v = 0$, or $t = 18/32 = 0.56$ seconds after it enters the window.

Exercise 2.9

A boat starts off with an initial velocity of v_0 to the right. Its velocity decreases exponentially as $v = v_0e^{-\alpha t}$ where α is a constant. What is the maximum distance to the right that the boat travels?

In this case, the acceleration is **not** constant. The formulas for constant acceleration do not apply here. Since we know $v(t)$, we can solve for $x(t)$ using $dx/dt = v$:

$$\begin{aligned} \frac{dx}{dt} &= v_0e^{-\alpha t} \\ \int dx &= \int v_0e^{-\alpha t} dt \\ x &= -v_0\frac{e^{-\alpha t}}{\alpha} + C \end{aligned}$$

where C is an integrating constant. Since $x = 0$ at $t = 0$, $C = v_0/\alpha$. Thus,

$$x(t) = \frac{v_0}{\alpha}(1 - e^{-\alpha t}) \quad (3)$$

As $t \rightarrow \infty$, $x \rightarrow v_0/\alpha$. So the maximum distance the boat travels is v_0/α .

Exercise 3.1

An object of mass 2 Kg is subject to two forces. One force is directed due East with

a magnitude of 8 Newtons. The other force is directed due North with a magnitude of 6 Newtons. If the object starts from rest at the origin, what is its position after 3 seconds?

We first need to find the net force on the object. The 8 Newton force is represented by the vector $8\hat{i}$, and the 6 Newton force by the vector $6\hat{j}$. Adding these two force vectors, we obtain the Net Force vector $\vec{F}_{net} = 8\hat{i} + 6\hat{j}$ Newtons. The magnitude of the net force is $|\vec{F}_{net}| = \sqrt{8^2 + 6^2} = 10$ Newtons. The direction of the net force is $\tan\theta = 6/8$ or $\theta \approx 37^\circ$ North of East. The acceleration equals the (Net Force)/mass, so the magnitude of the acceleration is

$$\begin{aligned} |\vec{a}| &= \frac{|\vec{F}_{net}|}{m} \\ &= \frac{10}{2} \\ &= 5 \text{ m/s}^2 \end{aligned}$$

Since the Net Force is constant, the acceleration will also be constant. The distance traveled for constant acceleration is $d = (a/2)t^2 + v_0t + x_0$. Since $x_0 = 0$ and $v_0 = 0$, the distance traveled after 3 seconds is

$$\begin{aligned} d &= \frac{5}{2}t^2 \\ &= \frac{5}{2}3^2 \\ &= 22.5 \text{ meters} \end{aligned}$$

So the object is 22.5 meters from the origin at an angle of 37° North of East.

Another way to solve the problem is to keep \vec{a} in component form. $\vec{a} = \vec{F}_{net}/m = (8\hat{i} + 6\hat{j})/2 = 4\hat{i} + 3\hat{j} \text{ m/s}^2$. The distance traveled after a time $t = 3$ seconds is:

$$\begin{aligned} \vec{d} &= \frac{\vec{a}}{2}t^2 \\ &= \frac{4\hat{i} + 3\hat{j}}{2}3^2 \\ &= 18\hat{i} + 13.5\hat{j} \text{ meters} \end{aligned}$$

The magnitude of \vec{d} is $\sqrt{18^2 + 13.5^2} = 22.5$ meters.

Exercise 3.2

A box of mass 4 Kg is on top of a table. There is friction between the box and the table. If a force of 10 Newtons is applied, the box moves with an acceleration of 2 m/s^2 . If a force of 14 Newtons is applied to the box, what will be its acceleration?

If the 10 Newton force were the only one acting, the box would have an acceleration of $a = 10/4 = 2.5 \text{ m/s}^2$. Since the acceleration is 2 m/s^2 , the Net Force equals $(4)(2) = 8$ Newtons. There must be another force of 2 Newton's acting on the box. We can assume that this is due to the friction between the box and the table. That is, the frictional force equals 2 Newtons.

Now if a force of 14 Newtons is applied to the box, the Net Force will be $14 - 2 = 12$ Newtons. The acceleration is thus, $a = 12/4 = 3 \text{ m/s}^2$.

Exercise 3.3

Consider the two blocks shown in the figure, which are on a frictionless surface. Block 1 has a mass of 12 Kg, and block 2 has a mass of 4 Kg. A force of 16 Newtons is applied to block 1. What force, F_{21} , does block 2 feel due to block 1. What force, F_{12} , does block 1 feel due to block 2?

The total mass is 16 Kg. The force of 16 Newtons will cause both masses to accelerate with a value $a = 16/16 = 1 \text{ m/s}^2$. Thus, the Net Force on the 4 Kg block must be $4(1) = 4$ Newtons. This force is due to block 1 pushing on block 2, this is F_{21} . $F_{21} = 4$ Newtons. Since block 1 has an acceleration of 1 m/s^2 , the net force on it must be $12(1) = 12$ Newtons. Since $F_{net} = 16 - F_{12}$, F_{12} must also equal 4 Newtons.

This is interesting. We see that \vec{F}_{21} is equal in magnitude but opposite in direction to \vec{F}_{12} . This is actually Newton's Third Law, however we only used Newton's second law to obtain it. For *contact forces*, Newton's Third law is a result of $F_{net} = ma$. Newton realized that this same "symmetry of forces" also applies to "action at a distance" forces, and is a separate law of nature.

Exercise 3.4

Consider the two blocks shown in the figure. Both blocks, one 5 Kg and one 10 Kg,

3.1

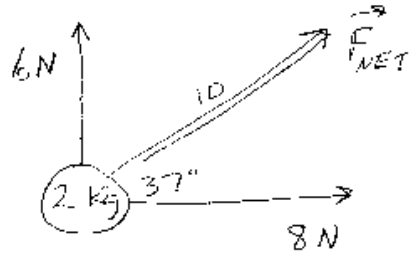

$$\vec{a} = \frac{\vec{F}_{NET}}{m}$$

$$|\vec{a}| = \frac{10}{2} = 5 \text{ m/s}^2$$

$$d = \frac{a}{2} t^2 = \frac{5}{2} (3)^2 = 22.5 \text{ m}$$

3.2

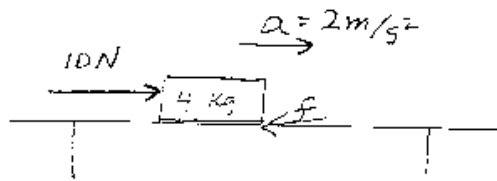

$$F_{NET} = ma$$

$$10 - f = 4(2)$$

$$f = 2 \text{ N}$$

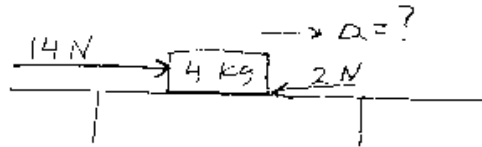

$$F_{NET} = ma$$

$$14 - 2 = 4a$$

$$a = 3 \text{ m/s}^2$$

are on a frictionless surface. They are connected by a massless cord. A force of 30 Newtons pulls the 10 Kg block to the right. What is the tension in the cord?

Let T be the tension in the cord. Since the cord is massless, this force T pulls the 5 Kg block to the right and it pulls the 10 Kg block to the left. The best way to analyse the motion is to treat each block separately. That is, first identify all the forces on a block and add them up to find the net force on the block. Then the acceleration of the block is $a = F_{net}/m$. Do this for each block.

In the vertical direction, each block is subject to the gravitational force (of the earth) plus the force that the table exerts on it. Since there is no motion in the vertical direction, the magnitudes of these two forces are equal, and the net vertical force on each block is zero. For the 5 Kg block, the only horizontal force is T . So $T = 5a$. For the 10 Kg block, there are two horizontal forces: 30 Newtons to the right and T to the left. The net force is $30 - T$. So we have $30 - T = 10a$. Now we have two equations with two unknowns, a and T . These can be solved to give $a = 2 \text{ m/s}^2$, and $T = 10$ Newtons.

Exercise 3.5

Consider the two blocks shown in the figure. The block with mass m slides without friction on the table. The other block, mass $3m$ hangs and is pulled downward with a force of $3mg$. The pulley and cord are massless. What is the acceleration of the system, and what is the tension T in the massless cord?

We can take the same approach as Exercise 3.4: Consider each object separately by finding the net force on each block, and applying $F_{net} = ma$ to each block. First the block on the table. There is no motion in the vertical direction for the block of mass m , so the force from the table balances the weight of this block. There is only one horizontal force on the block on the table, T . Thus, we have $T = ma$. For the hanging block there is only motion in the vertical direction. The net force in the vertical direction is $3mg - T$. The magnitude of the acceleration for each block is the same, so we have $3mg - T = 3ma$. We have two equations with two unknowns:

$$\begin{aligned} T &= ma \\ 3mg - T &= 3ma \end{aligned}$$

Adding these equations eliminates T , and gives $3mg = 4ma$. So $a = 3g/4$, and $T = 3mg/4$. Note that eventhough one block moves horizontally and the other vertically, they are coupled by the cord and are essentially a system moving in one

3.3

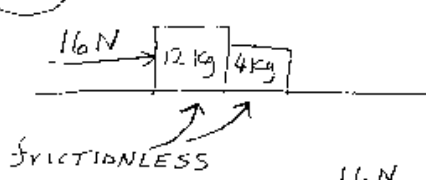

$$a = \frac{16\text{ N}}{16\text{ kg}} = 1\text{ m/s}^2$$

$$a = 1\text{ m/s}^2$$

$$a = 1\text{ m/s}^2$$

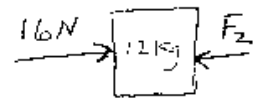

$$16 - F_2 = 12a$$

$$16 - F_2 = 12(1) = 12$$

$$F_2 = 4\text{ N}$$

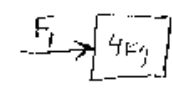

$$F_1 = ma = 4(1) = 4\text{ N}$$

$$F_1 = 4\text{ N}$$

3.4

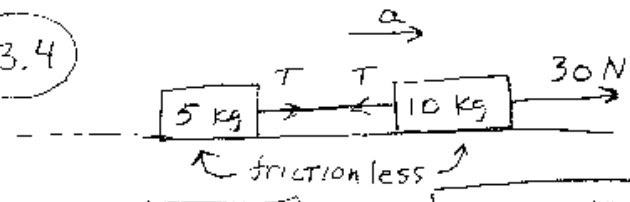

$$T = 5a$$

$$30 - T = 10a$$

$$a = 2\text{ m/s}^2 \quad T = 10\text{ N}$$

3.5

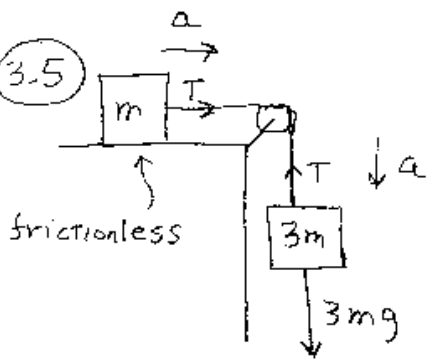

$$T = ma$$

$$3mg - T = 3ma$$

$$3mg = 4ma$$

$$a = \frac{3}{4}g$$

$$T = \frac{3}{4}mg$$

dimension.

/bigskip

Exercise 3.6

A 10 Kg block is hanging inside of an elevator that is in a building on the earth.

a) If the elevator moves with a constant velocity upward of 3 m/s what is the tension T in the cord?

Since the block has a constant velocity, the acceleration of the block is *zero* with respect to the earth. Since the acceleration is zero, the net force on the block must be *zero*. The net force is $mg = 10(9.8) = 98$ Newtons downward plus T upward. Since this sum must be zero, we have $T - 98 \text{ Newtons} = 0$ or $T = 98$ Newtons.

b) In figure b), the tension in the cord is 88 Newtons. What is the elevator doing?

The net force on the block is T upward and mg downward. Letting the $+$ direction be upward, we have $F_{net} = T - mg = 88 - 10(9.8) = -10$ Newtons. Since the acceleration equals the net force divided by mass, we have $a = -10/10 = -1 \text{ m/s}^2$. The acceleration of the elevator (and the block) with respect to the earth is 1 m/s^2 downward. We do not know if the velocity is upward or downward! The elevator could be moving upward and slowing down, or moving downward with increasing speed. The direction of the acceleration is not related to the direction of the velocity!

Exercise 3.7

Chone hits the baseball with a speed of 100 m/s at an angle of 37° with respect to the horizontal. The fence is 10 feet high and located 280 feet from home plate. Does Chone hit a Home Run?

The force on the ball is due to gravity, which equals $m\vec{g}$. Taking up to be the $+y$ direction, the force is $-mg\hat{j}$. The acceleration of the ball is $\vec{a} = -mg\hat{j}/m = -g\hat{j}$. So, if we neglect air friction, the acceleration of the ball is $-g\hat{j}$ no matter what the mass of the ball is. Let the position vector $\vec{r}(t) = x(t)\hat{i} + y(t)\hat{j}$. Since the acceleration is only in the "y" direction and constant, $x(t)$ increases with a constant velocity, and the motion in the y-direction is one of constant acceleration. We can analyze $x(t)$ and $y(t)$ independently.

At $t = 0$, $\vec{v}_0 = 100\cos(37^\circ)\hat{i} + 100\sin(37^\circ)\hat{j} \approx 80\hat{i} + 60\hat{j}$ ft/s. Using $g = 32$ ft/s² on earth, we have:

$$\begin{aligned}x(t) &= 80t \\y(t) &= 60t - 16t^2\end{aligned}$$

The time it takes the ball to reach the fence is found by solving $280 = 80t$, or $t = 3.5$ seconds. The height of the ball at 3.5 seconds is $y(3.5) = 60(3.5) - 16(3.5)^2 = 14$ feet. So the ball does go over the fence. Chone hits a home run.

We can ask other questions:

b) What is the velocity of the ball at its maximum height?

The velocity of the ball at any time is found by differentiating the position: $\vec{v}(t) = (80\hat{i} + (60 - 32t)\hat{j})$ m/s At the maximum height, $v_y = 0$, so $\vec{v} = 80\hat{i}$.

c) How long does it take the ball to reach its maximum height?

At the ball's maximum height, $v_y = 0 = 60 - 32t$. Solving for t gives $t = 60/32 = 1.875$ seconds.

d) What is the maximum height of the ball? What is h in the figure?

The maximum height is just $y(1.875 \text{ seconds})$. This is just $60(1.875) - 16(1.875)^2 = 56.25$ feet.

Exercise 3.8

Suppose we have a giant box that can slide without friction on an inclined plane. Let the angle that the incline makes with the horizontal be θ , and the mass of the box m . What is acceleration of the box on the incline?

There are two forces on the box: its gravitational weight and the force that the incline exerts on it. The weight of the box is $\vec{W} = m\vec{g}$. Since there is no friction, the force that the incline can exert on the box can only be perpendicular to its surface. We label this force as \vec{N} . Let \vec{F}_{net} be the net force on the box. Since the motion is down the incline, \vec{F}_{net} must point down the plane. Thus, \vec{N} , $m\vec{g}$, and \vec{F}_{net} must

3.6

a

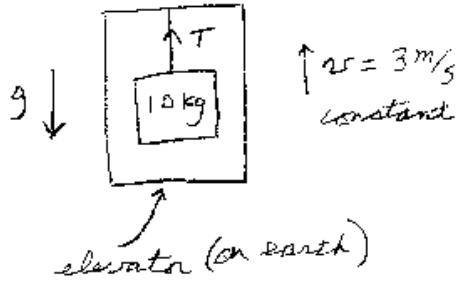

b

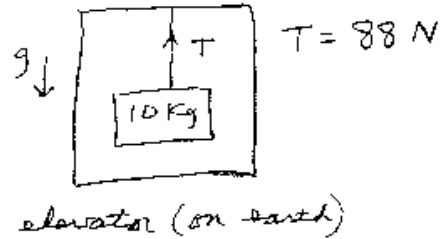

3.7

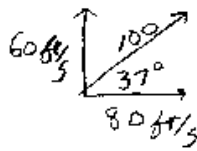
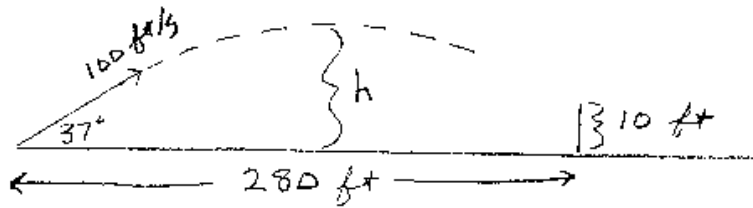

$$x(t) = 80t$$

$$y(t) = 60t - 16t^2$$

$$v_x = 80$$

$$v_y = 60 - 32t$$

Time to reach fence:

$$280 = 80t \Rightarrow t = 3.5 \text{ sec}$$

$$y(3.5) = 60(3.5) - 16(3.5)^2 = 14 \text{ ft} \quad \text{yep, a home run}$$

$$\text{at max height } v_y = 0 \Rightarrow t = \frac{60}{32} = 1.875 \text{ sec}$$

$$h = 60(1.875) - 16(1.875)^2 = 56.25 \text{ ft}$$

form the triangle shown in the figure. From the triangle we see that $|\vec{F}_{net}| = mg\sin\theta$. Since the acceleration is the (net force)/mass, the acceleration of the box down the plane is constant and equal to $a = g\sin\theta$. We can check the limits of this result. If $\theta = 0$, $a = g\sin(0) = 0$ as it should. If $\theta = 90^\circ$, then $a = g\sin 90^\circ = g$ as it should for free fall. Note that the acceleration is the same no matter what the mass of the box is.

Another approach to solve this problem is to "break up" the weight vector $\vec{W} = m\vec{g}$ into the sum of two vectors: one down the incline and one perpendicular to the incline. \vec{W} must equal the vector sum of these two vectors. Since $m\vec{g}$ is the hypotenuse of the triangle, the vector down the incline has a magnitude of $mg\sin\theta$. The vector perpendicular to the incline has a magnitude of $mg\cos\theta$. Since there is no motion perpendicular to the incline, $|\vec{N}| = mg\cos\theta$, and the acceleration down the incline is $g\sin\theta$ independent of m as before.

It is interesting to ask the following question. Suppose a person of mass M were inside the box as it is accelerating down the incline. If this person stood on a scale, what would the scale read? The scale would read the normal force acting on the person, which is $Mg\cos\theta$. The person in the box would feel the same as if he/she were on a planet with a gravitational acceleration of $9.8\cos\theta$ m/s^2 . This is a nice way to train astronauts for life on another planet.

Exercise 3.9

A 5 Kg block is subject to a 10 Newton force to the right.

a) For the surface in figure a), the block moves with a **constant velocity**. What is the coefficient of friction between the block and the surface?

Since the velocity is constant, the acceleration is zero. This means that the frictional force f exactly balances out the 10 Newton force. Thus, the magnitude of f equals 10 Newtons. Since f is the normal force times the coefficient of friction μ , we have $\mu mg = 10$. This equation gives $\mu = 10/(mg) = 10/((5)(9.8)) \approx 0.2$.

b) For the surface in figure b), the block accelerates to the right with an acceleration of 1.5 m/s^2 . Since $F_{net} = ma$, we have $10 - f = 5a$. The frictional force f equals the normal force (mg) times μ , we have $10 - mg\mu = 5(1.5)$. This equation yields $\mu = (10 - 7.5)/((5)(9.8)) \approx 0.051$.

Exercise 3.10

In figure 3.10, one block, mass m , moves on the top of a table. The coefficient of

3.8

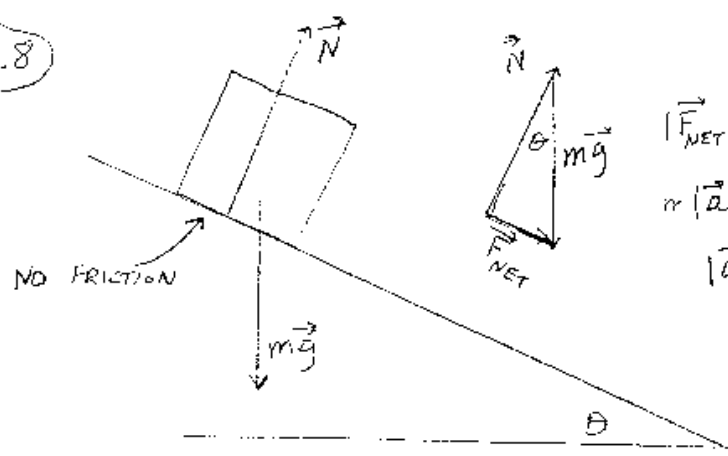

$$|\vec{F}_{NET}| = mg \sin \theta$$
$$m|\vec{a}| = mg \sin \theta$$
$$|\vec{a}| = g \sin \theta$$

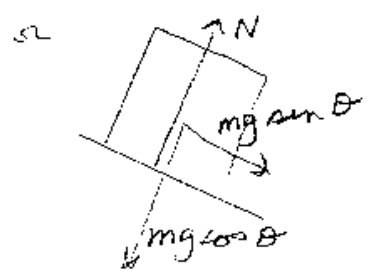

$$m|\vec{a}| = mg \sin \theta$$
$$|\vec{a}| = g \sin \theta$$
$$|\vec{N}| = mg \cos \theta$$

kinetic friction μ between the block and the table is $\mu_k = 0.5$. Another block, mass $3m$, is attached by a massless cord to the block on the table. The cord passes over a massless pulley. What is the acceleration a of the system?

This problem is similar to 3.5 except there is friction between the block and the table. The method to solve this problem is the same as before: to determine the net force on each block, and then apply $F_{net} = ma$ to each block. Since the cord and pulley are massless, the tension T in the cord is the same for both blocks. Let the $+$ direction be the direction of motion for each block: down for the $3m$ block and to the right for the m block. For the hanging block we have $3mg - T = 3ma$. For the block on the table we have $T - f = ma$, where f is the frictional force. The frictional force equals μ times the normal force of mg . Thus, for the block on the table we have $T - \mu mg = ma$:

$$\begin{aligned} T - \mu mg &= ma \\ 3mg - T &= 3ma \end{aligned}$$

If one adds these two equations, the T cancels and we have $3mg - \mu mg = 4ma$, yielding $a = g(3 - \mu)/4 = 0.625g$. From the first equation we can solve for the tension T : $T = \mu mg + ma = 0.5mg + 0.625mg = 1.125mg$.

Exercise 3.11

A block of mass m slides down an inclined plane. The plane makes an angle of θ with the horizontal. The coefficient of kinetic friction between the block and the plane is μ_k . What is the acceleration of the block down the plane?

This is similar to 3.8, except there is friction between the block and the incline. As before, the best way to solve the problem is to "break-up" the force of gravity into two pieces: a force down the plane, $mgsin\theta$, and a force perpendicular to the plane, $mgcos\theta$. Since there is no motion perpendicular to the plane, the normal force must equal $mgcos\theta$. The frictional force $f = \mu N = \mu mgcos\theta$. This force is opposite to the direction of motion, so we have:

$$\begin{aligned} ma &= F_{net} \\ ma &= mgsin\theta - \mu mgcos\theta \\ a &= g(sin\theta - \mu cos\theta) \end{aligned}$$

If $\mu = 0$, we obtain the result of Exercise 3.8, $a = g\sin\theta$. If the block is sliding, then μ is the coefficient of kinetic friction. It is interesting to note that the mass of the block cancels out. So the acceleration is the same for any block even if the friction is proportional to the normal force. Also note that in this case the normal force is $mg\cos\theta$, and not just mg . This is because the block "pushes" on the incline with a force of $mg\cos\theta$.

If $\mu > \tan\theta$ then the block will not slide down the plane at all. If the block is moving, then it will come to rest. This is the case when you are trying to stop your car while going downhill. The net force slowing you down is $mg\mu\cos\theta - mg\sin\theta$. The acceleration is $-g(\mu\cos\theta - \sin\theta)$. If $\theta = 0$, the acceleration is $-\mu g$, and for inclines it becomes more difficult to stop your car. To stop a car, the coefficient is μ_{static} if you do not skid, and $\mu_{kinetic}$ if you do skid.

Exercise 3.12

You have a suitcase of mass m that you want to drag across the floor with a constant velocity. You pull on it with a force F at an angle of θ . The coefficient of kinetic friction between the suitcase and the floor is μ . Find an expression for F in terms of m , μ , and θ .

The best way to approach this problem is to "break-up" the force \vec{F} into its "components": $\vec{F} = F\cos\theta\hat{i} + F\sin\theta\hat{j}$. The forces in the horizontal direction are $F\cos\theta - f$, where f is the frictional force acting to the left. The forces in the vertical direction are $F\sin\theta + N - mg$, where N is the "normal" force that the floor exerts on the suitcase. Note that the normal force is not equal to mg . This is because part of the force \vec{F} , $F\sin\theta$, lifts the box up reducing the normal force. The normal force is $mg - F\sin\theta$. Since the acceleration is zero, the sum of the forces in each of these directions must equal zero:

$$\begin{aligned} F\cos\theta - f &= 0 \text{ (horizontal direction)} \\ N + F\sin\theta - mg &= 0 \text{ (vertical direction)} \end{aligned}$$

We can solve the second equation for N : $N = mg - F\sin\theta$. Since $f = \mu N$, we have $F\cos\theta = f = \mu N = \mu(mg - F\sin\theta)$. Solving for F yields:

$$F = \frac{\mu mg}{\cos\theta + \mu\sin\theta} \quad (4)$$

3.9

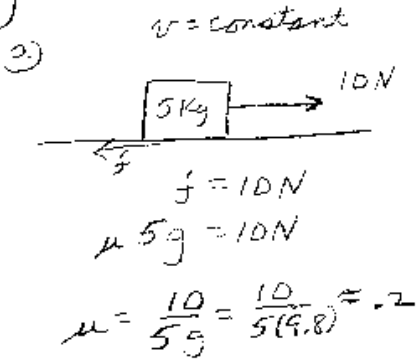

b)

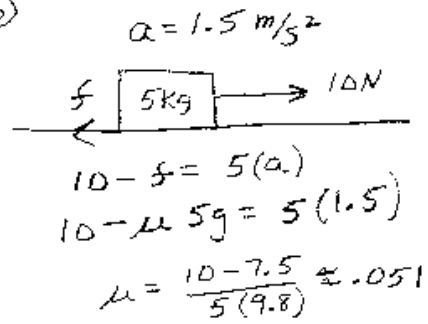

3.10

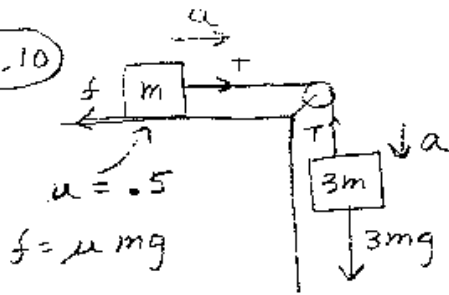

$$T - \mu mg = ma$$

$$3mg - T = 3ma$$

$$3mg - \mu mg = 4ma$$

$$a = \frac{g(3 - \mu)}{4} \approx 0.625g$$

3.11

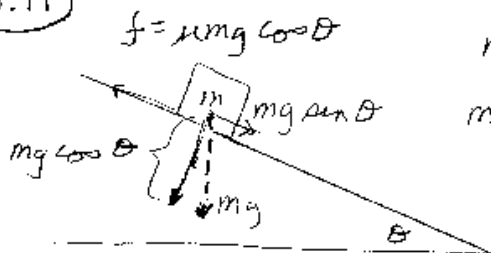

$$mg \sin \theta - f = ma$$

$$mg \sin \theta - \mu mg \cos \theta = ma$$

$$a = g(\sin \theta - \mu \cos \theta)$$

From this equation one can see that the force F needed to drag the suitcase across the floor with a constant velocity depends on the angle. F will be minimized for a special angle. To find this angle, one needs to differentiate F with respect to θ and set the derivative equal to zero: $dF/d\theta = 0$. Take the derivative and solve this equation and you will find that the best angle for dragging the suitcase is when $\theta = \tan^{-1}\mu$.

Exercise 3.13

A force of magnitude F is applied to the block of mass m_1 shown in the figure. m_1 can slide without friction on a horizontal surface. Another block of mass m_2 is touching m_1 . There is friction between the two blocks, with the coefficient of static friction being μ . m_2 is not touching the horizontal surface, but is being held up by the frictional force between the blocks. That is, the force F is large enough so that the frictional force between the blocks can keep m_2 from sliding down m_1 . What is the minimum value that F can be.

Since both blocks move with the same acceleration, the acceleration is the force over the total mass: $a = F/(m_1 + m_2)$. The only *horizontal* force that m_2 feels is the force that m_1 exerts on it. This force is labeled c in the figure. c is also the Normal force between the two surfaces. If the block m_2 is held up by the frictional force f , then $f = m_2g$. The maximum that f can be is μc , thus for the block m_2 not to slip, we must have $\mu c \geq m_2g$. However, from Newton's second law, $c = m_2a$, we have:

$$\begin{aligned} f &= m_2g \\ \mu c &\geq m_2g \\ \mu m_2 a &\geq m_2g \\ \mu m_2 \frac{F}{m_1 + m_2} &\geq m_2g \\ F &\geq \frac{(m_1 + m_2)g}{\mu} \end{aligned}$$

It is interesting to note that in this case the direction of the normal force is horizontal. The normal force is *perpendicular to the surface*, and not necessarily in the direction of \vec{g} .

Exercise 3.14

You are driving your car with a speed of 60 MPH (88 ft/s) and apply the brakes.

3.12 constant $v \rightarrow$

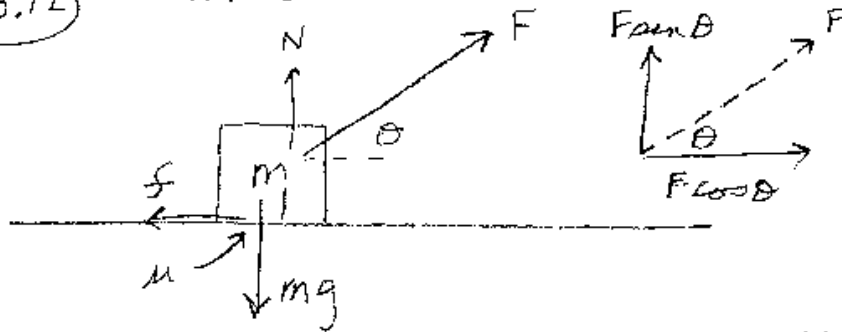

$$\begin{cases} N + F \sin \theta - mg = 0 & \Rightarrow N = mg - F \sin \theta \\ F \cos \theta - f = 0 \\ F \cos \theta = f = \mu N = \mu (mg - F \sin \theta) \end{cases}$$

$$F = \frac{\mu mg}{\cos \theta + \mu \sin \theta}$$

$$\frac{dF}{d\theta} = 0 \Rightarrow \theta = \tan^{-1} \mu$$

3.13



NO FRICTION

$$a = \frac{F}{m_1 + m_2}$$

$$c = m_2 a$$

$$\begin{aligned} f &\geq m_2 g \\ \mu m_2 a &\geq m_2 g \\ \frac{\mu m_2 F}{m_1 + m_2} &\geq m_2 g \Rightarrow F \geq \frac{(m_1 + m_2) g}{\mu} \end{aligned}$$

How far do you travel before you stop?

When you apply the brakes, the force that slows the car down is the frictional force between the tires and the road. The frictional force is proportional to the normal force, $f = \mu N$. In our case, $N = mg$, so we have $f = \mu mg$. The acceleration of the car is the (net force)/m: $a = -(\mu mg)/m = -\mu g$. Let the car have an initial speed of v_0 . The final speed is $v_f = 0$. Since the acceleration is constant, we have

$$\begin{aligned}v_f^2 &= v_0^2 + 2a(x - x_0) \\0 &= v_0^2 - 2\mu g(x - x_0) \\(x - x_0) &= \frac{v_0^2}{2\mu g}\end{aligned}$$

From this equation, one can see that the distance traveled increases as the *square* of the speed. If you double your speed it will take you 4 times the distance to come to a stop. The value of μ depends on how you apply the brakes.

a) If you slam on the brakes and **skid** to a stop, then μ is the coefficient of kinetic friction, μ_k , and will be small, around 0.5. In this case you will travel a distance of

$$(x - x_0) = \frac{(88 \text{ ft/s})^2}{2(0.5)32 \text{ ft/s}^2} = 242 \text{ ft} \quad (5)$$

b) If you don't skid to a stop, then the largest that f can be is μ_s , the coefficient of static friction. Static friction is relevant because if you don't skid, the surfaces are not sliding "on" each other. μ_s is usually greater than μ_k , so you can stop in a shorter distance. Taking μ_s to be 0.6 we have

$$(x - x_0) = \frac{(88 \text{ ft/s})^2}{2(0.6)32 \text{ ft/s}^2} \approx 202 \text{ ft} \quad (6)$$

Modern cars have a built in ABS system which prevent the car from skidding when the brakes are applied.

Exercise 3.15

The coefficient of static friction between your tires and the road is μ_s . You drive your car around a curve that has a radius r . What is the maximum speed you can drive

without having the car skid off the road?

In order to travel in a circle of radius r with constant speed v , i.e. uniform circular motion, the net force on the car must be directed towards the center and be of magnitude mv^2/r . The source of this force must be the static frictional force on the tires from the road, since it is the only one that acts horizontally. The largest that this frictional force can be is $\mu_s mg$ where μ_s is the coefficient of static friction. So we have:

$$\begin{aligned} F_{max} &= \mu_s mg \\ \frac{mv_{max}^2}{r} &= \mu_s mg \\ v_{max} &= \sqrt{\mu_s gr} \end{aligned}$$

Exercise 3.16

Suppose that for the car of exercise 3.15 the road is banked. Let θ be the angle that the road makes with the horizontal. Now, what is the maximum speed that the car can go without skidding off the road?

As before, in order to travel in a circle of radius r with constant speed v , the net force must be directed towards the center and be of magnitude $|\vec{F}_{net}|mv^2/r$. This problem is more complicated than 3.15, since there are more forces, 3, that have a component in the horizontal direction. From the figure, we must have

$$\vec{F}_{net} = \vec{N} + m\vec{g} + \vec{f} \quad (7)$$

where \vec{f} is the static frictional force. A convenient coordinate system is one that has the "x-axis" parallel to the banked road, and the "y-axis" perpendicular to the road. In this case, the equations for each axis become:

$$\begin{aligned} f + mg\sin\theta &= F_{net}\cos\theta \quad (x - axis) \\ N - mg\cos\theta &= F_{net}\sin\theta \quad (y - axis) \end{aligned}$$

where $F_{net} = mv^2/r$. The maximum static friction force is $f_{max} = \mu N$. With this substitution we have

$$\begin{aligned}\mu N + mg\sin\theta &= \frac{mv_{max}^2}{r}\cos\theta \\ N - mg\cos\theta &= \frac{mv_{max}^2}{r}\sin\theta\end{aligned}$$

Eliminating N from these equations gives

$$\frac{mv_{max}^2}{r}\cos\theta - mg\sin\theta = \mu\left(\frac{mv_{max}^2}{r}\sin\theta + mg\cos\theta\right) \quad (8)$$

Solving for v_{max} yields

$$v_{max} = \sqrt{\frac{rg(\sin\theta + \mu\cos\theta)}{\cos\theta - \mu\sin\theta}} \quad (9)$$

It is interesting to check the limiting cases for this result. If $\theta = 0$, we obtain the result of 3.15, $v_{max} = \sqrt{rg\mu}$. If $\mu = 0$, then the car can make the turn with a speed of $v = \sqrt{rg\tan\theta}$ without needing any help from the frictional force. In this case $\vec{F}_{net} = \vec{N} + m\vec{g}$. If $\mu > \cot\theta$, then v_{max} is infinity. That means that the car can never skid off the road. In this case if the car goes too slow, it will slide down the road.

Exercise 3.17

Julian likes to swing on a swing. He would like to know how fast he is traveling at the bottom of his swing. To do this he sits on a scale which measures his weight. He also measures the length of the swing's rope to be 12 feet. When Julian just sits on the scale without swinging the scale reads 96 pounds. He now swings. When he is at the lowest point in his swing he notices that the scale reads 132 pounds. How fast is Julian moving at the bottom of his swing?

At the bottom of his swing, the forces on Julian are all in the vertical direction. Since the motion is circular with radius r , the net force at the bottom of the swing must be upward with a magnitude of mv^2/r where v is his speed at the bottom. The net force is the sum of the upward force from the swing seat (132 pounds) and gravity (96 pounds) downward. Thus, we have

$$\frac{mv^2}{r} = N - mg$$

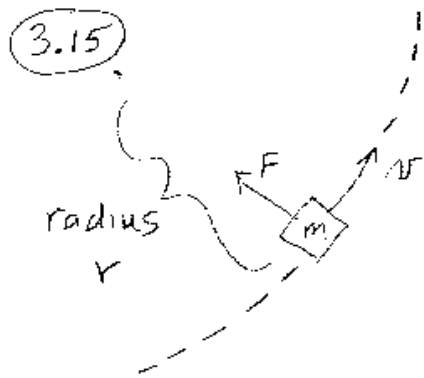

$$a = \frac{v^2}{r}$$

$$F = ma = \frac{mv^2}{r}$$

$$F_{\max} = \mu_s mg$$

$$\frac{mv_{\max}^2}{r} = \mu_s mg$$

$$v_{\max} = \sqrt{\mu_s g r}$$

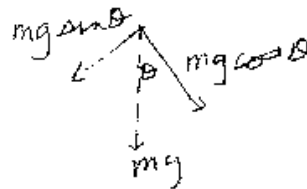
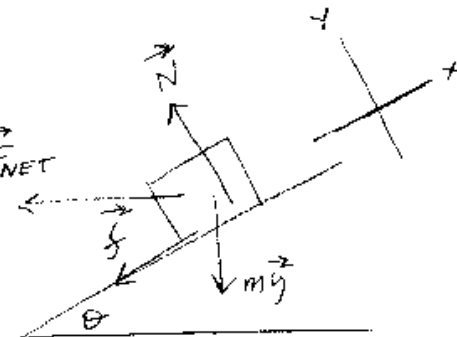
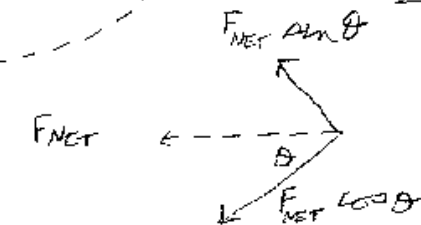
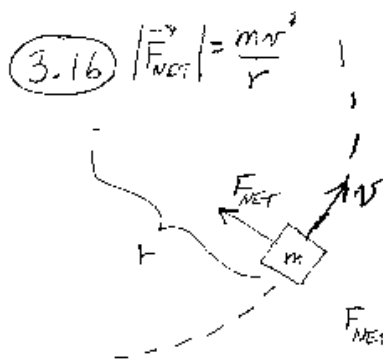

$$f + mg \sin \theta = F_{\text{NET}} \cos \theta$$

$$N - mg \cos \theta = F_{\text{NET}} \sin \theta$$

$$f \leq \mu N$$

$$F_{\text{NET}} = \frac{mv^2}{r}$$

$$\frac{mv^2}{r} \cos \theta - mg \sin \theta \leq \mu \left(\frac{mv^2}{r} \sin \theta + mg \cos \theta \right)$$

$$v_{\max} = \sqrt{rg (\sin \theta + \mu \cos \theta) / (\cos \theta - \mu \sin \theta)}$$

$$\frac{mv^2}{12} = 132 - 96$$

Julian's mass is found from $W = mg$. Since his weight is 96 pounds, we have $m = 96/32 = 3$ slugs. Plugging in we have

$$\begin{aligned} \frac{3v^2}{12} &= 36 \\ v &= 12 \text{ ft/s} \end{aligned}$$

Exercise 3.18

Harvey spins the "twirl-a-bob". The twirl-a-bob is shown in Figure 3.18. A small ball of mass m_1 moves in a horizontal circle of radius r with speed v . A string, which makes an angle of θ with the vertical is attached to the ball. The string goes through a cylindrical tube and is pulled down by a block of mass m_2 . The block (mass m_2) is stationary, that is, its weight is balanced by the tension in the string. Determine what the angle θ is in terms of the parameters of the system.

There are two forces on the ball: its weight $\vec{W} = m_1\vec{g}$, and the force the string exerts, the tension \vec{T} . Since m_2 's weight is balanced by the tension in the string, $|\vec{T}| = m_2g$. The ball is traveling in a circle of radius r with constant speed v , so the net force on it, which is the sum of $m_1\vec{g}$ and \vec{T} , must be equal to m_1v^2/r directed towards the center of the circle. Thus the three forces, m_1g , m_2g , and m_1v^2/r , form a right triangle as shown in the figure. In this triangle, we have $\tan\theta = (m_1v^2/r)/(m_1g)$, or $\tan\theta = v^2/(rg)$. We also have $\cos\theta = (m_1g)/(m_2g)$, or

$$\cos\theta = \frac{m_1}{m_2} \tag{10}$$

This last equation is a rather amazing result. If m_1 is moving in a steady circle, the angle the string makes is simply $\cos^{-1}m_1/m_2$. An interesting effect occurs if we start the twirl-a-bob going in a circle and hold the tube still. As the ball m_1 slowly loses energy, the radius r will decrease as the mass m_2 slowly drops. However, since the angle θ only depends on the ratio of the masses m_1/m_2 , the angle θ will not change as m_1 slows down. The angle θ will remain constant as m_1 moves toward the top of the tube. We will demonstrate this in lecture.

3.17

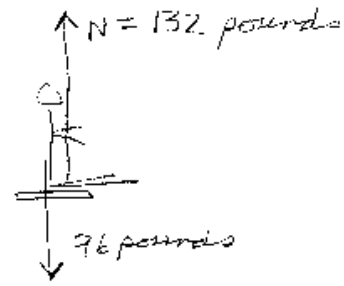
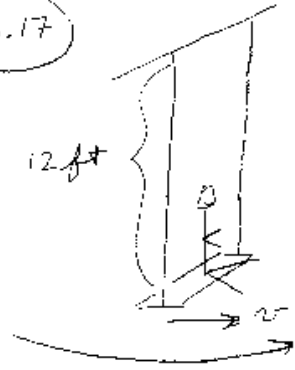

$F_{NET} = 132 - 96 = 36 \text{ pounds upward}$

$$F_{NET} = ma$$

$$36 = \frac{m_1 v^2}{r} = m_1 g \frac{v^2}{gr}$$

$$36 = \frac{96 v^2}{32(12)}$$

$v = 12 \text{ ft/s}$

3.18

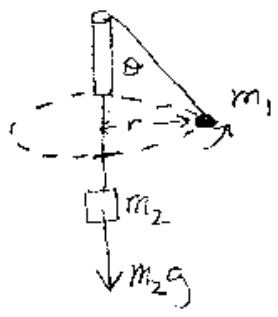

$|\vec{F}_{NET}| = \frac{m_1 v^2}{r}$

$\tan \theta = \frac{m_1 v^2 / r}{m_1 g}$

$\tan \theta = \frac{v^2}{rg}$

$\cos \theta = \frac{m_1 g}{m_2 g}$

$\cos \theta = \frac{m_1}{m_2}$

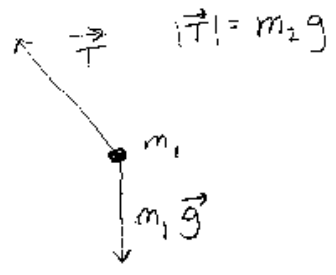
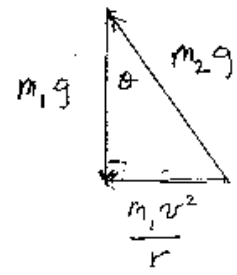

Exercise 3.19

We live on a rotating earth. Why can't we feel this rotation?

Let's calculate the acceleration at the equator due the circular motion of a person standing there. If you are standing on the equator, your speed due to the rotation of the earth is $v = (\text{circumference})/T = (2\pi R)/T$, where R is the radius of the earth and T is the time for one revolution. The radius of the earth is $r \approx 6.37 \times 10^6$ meters. The time for one complete rotation of the earth is $24(60)(60)$ seconds, so

$$\begin{aligned}v &= \frac{2\pi(6.37 \times 10^6)}{24(60)(60)} \\v &\approx 463 \text{ m/s}\end{aligned}$$

Wow, we are moving quite fast! The acceleration due to our circular motion is

$$\begin{aligned}a &= \frac{v^2}{R} \\a &\approx \frac{463^2}{6.37 \times 10^6} \\a &\approx 0.034 \text{ m/s}^2\end{aligned}$$

So the acceleration due to our uniform circular motion from the rotating earth is only 0.034 m/s^2 . This is only around 0.3% of g . This is why we can't feel the rotation. Eventhough we are traveling 463m/s we feel like we are at rest. We can only "notice" acceleration of our reference frame, not velocity.

Exercise 3.20

Suppose the earth didn't have an atmosphere, that is no air friction. How fast would you have to throw a baseball so that it traveled all the way around the earth (just above the surface) and returned to hit you in the back of the head?

The net force on the baseball is just $m\vec{g}$. As the ball travels around the earth, \vec{g} always points towards the center of the earth. For uniform circular motion, the acceleration is v^2/r . In the case of the baseball traveling in a circle just above the earth's surface, $r = R$, where $R = 6.37 \times 10^6$ meters is the radius of the earth. Thus, we have

$$\begin{aligned} |\vec{F}_{net}| &= m|\vec{a}| \\ mg &= \frac{mv^2}{R} \\ g &= \frac{v^2}{R} \\ v &= \sqrt{Rg} \\ v &\approx \sqrt{(6.37 \times 10^6)(9.8)} \\ v &\approx 7900 \text{ m/s} \end{aligned}$$

Wow, even the best baseball pitchers don't throw the ball that fast. If the surface of our earth was moving that fast, we would all just float above the surface along with everything else.